



# Machine Safety – Safeguards & Lockout

## What Every Supervisor should Know

Presented By BHHC Loss Control

June 2025

# Introduction

**226 (5.7%)**

Number of Caught in Machinery Fatalities and the percentage of all occupational fatalities for 2023

**29 CFR 1910.212**

29 CFR 1910.212 outlines the general requirements for machine guarding to protect operators and other employees from hazards such as point of operation, ingoing nip points, rotating parts, flying chips, and sparks. One of OSHA's Top 10 Cited Standards.

**50% Risk Reduction**

Proper machine guarding and lockout/tagout procedures can reduce the risk of caught-in machinery injuries by up to 50%

# Fatality at a Manufacturer

- On September 20, 2018, at approximately 11:00 a.m., an 18-year-old Hispanic male laborer suffered fatal injuries when he was pulled into the auger of a pug mill.
- The victim was an 18-year-old Hispanic male who had been on the job for only one month. He was hired as a laborer to package the finished product in the proper container and stack it on a pallet for shipment. He was born in the United States and spoke both English and Spanish. He was assigned to work with his stepbrother who was a machine operator.
- Key contributing factors identified in this investigation include:
  - Ensure that machinery with moving parts is properly guarded.
  - Ensure that new employees are adequately supervised while working with or near operating machinery.

**Title :** An 18-Year-Old Laborer Dies When Pulled into a Clay Molding Machine (Pug Mill)

**Personal Author(s) :** Cierpich, Hank;Styles, Laura;Harrison, Robert;

**Corporate Author(s) :** California Fatality Assessment and Control Evaluation Program (CA/FACE);California. Department of Public Health. Occupational Health Branch;

**Published Date :** 2019/06/24

**Pages in Document :** 1-7

**Series :** Fatality Assessment and Control Evaluation Reports (FACE)

**DOI :**

<https://doi.org/10.26616/NIOSHFACE18CA003>

# Fatality Investigation



Auger that caused fatality vs. Auger in same machine properly guarded



- Recommendation #1: **Ensure that machinery with moving parts is properly guarded.**
- Recommendation #2: **Ensure that new employees are adequately supervised while working with or near operating machinery.**

Exhibit 3. A pug mill with safety chute covering the auger blades.

Source – NIOSH FACE reports

June 2025

1. Understand the common hazards associated with moving machinery
2. Review the regulations and standards for machine safeguarding
3. Discuss the components of strong hazard recognition for machinery hazards
4. Identify the necessary steps to achieve a Zero Energy State when working on machinery

# Focus Caught In Machinery

Activities Being Performed - Caught in Machinery

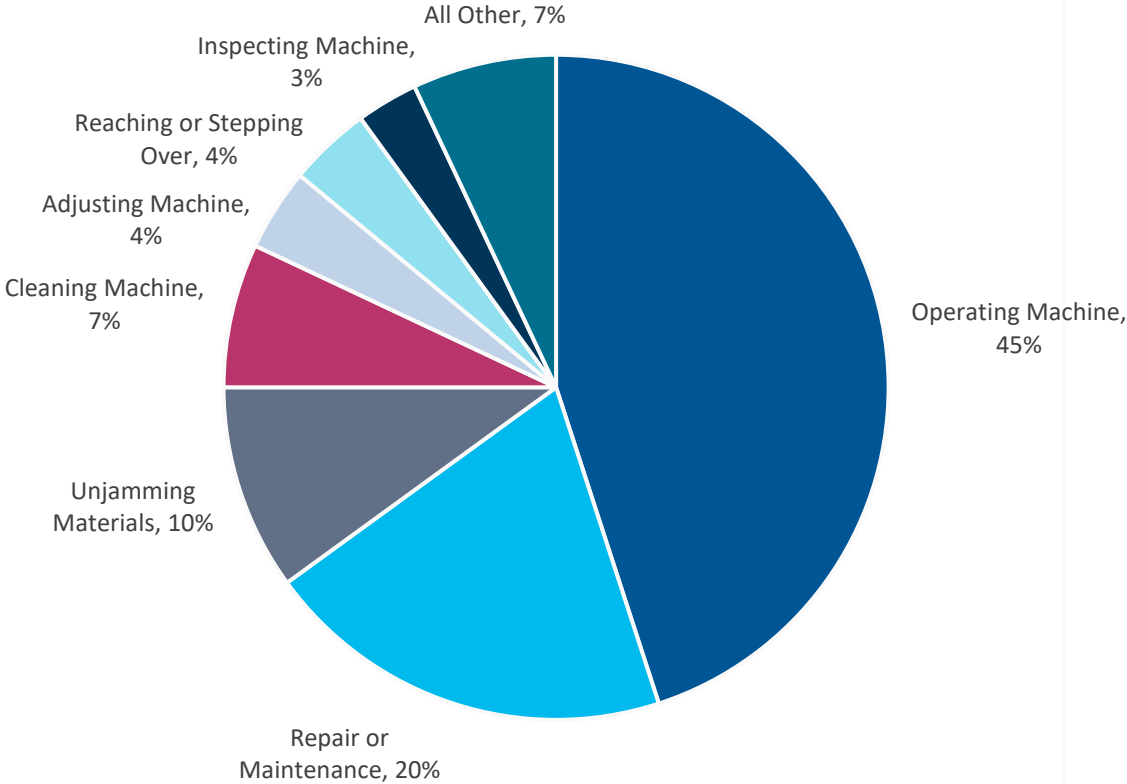

Source – Statistics from BLS

# 41%

Percent of Fatalities in the manufacturing industry that result from caught in operating machinery

# 19,000

Non-Fatal caught in operating machinery in *Manufacturing* in 2023

# 5.84 fps

Travel speed at point of operation for punch press doing 350 12-inch strokes per minute.

# .17 Sec

The light curtain must stop the stroke of the press in approximately 0.17 seconds if it is positioned 1 foot from the point of operation.

# We will focus on Best Practices....

...with a hint of compliance. Why?

- The goal of machine safeguarding effort is to prevent injuries and increase the lifespan of machinery.
- Regulatory standards are *minimum* requirements. Best in class employers go above and beyond.
- Remember that every workplace is different. Find the risk potential and address it proactively.

From: World Construction Today



# Basic Machinery Parts and Hazards



Three fundamental machine areas:

- Point of operation
- Power transmission device
- Operating controls – mechanical or electric power control

Source: OSHA

# The Point of Operation

Table Saw



Drill Press



Lathe

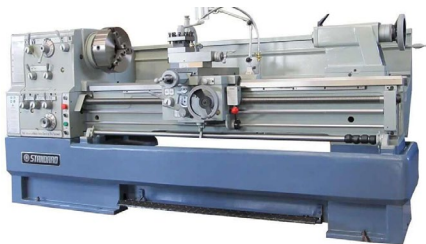

Grinder



## Point of operation

- Where work is performed on material
  - Cutting
  - Shaping
  - Boring
  - Forming

# Power Transmission Devices

- **Belts and Pulleys:** Belts provide flexible power transmission with high efficiency and low noise.
- **Chains and Sprockets:** Chains are durable and capable of transmitting high power over long distances. Sprockets help maintain exact speed ratios.
- **Gear Drives:** Gears provide precise speed ratios and torque transmission with high efficiency.
- **Shaft Drives:** Shafts are rigid components that transmit power through mechanical contact.
- **Power Screws:** Used as power transmission linkage elements, power screws convert rotational motion into linear motion



Driven Gear :  
 $Z_2 = 60$   
 $n_2 = 200\text{rpm}$

Driving Gear :  
 $Z_1 = 30$   
 $n_1 = 400\text{rpm}$

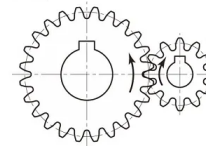

“Power transmission devices are parts that transmit energy to the component of the machine performing work:

- Flywheels
- Pulleys
- Belts
- Connecting rods
- Couplings
- Cams
- Spindles
- Chains
- Cranks
- Gears

# Operating Controls

## Operating Controls

- Start/Stop Buttons
- Emergency Stop (E-Stop) Controls
- Programmable Logic Controllers (PLCs)
- Foot Pedals
- Touchscreen Interfaces
- Handheld Remote Controls
- Safety Interlocks
- Variable Speed Controls



# Hazardous Motions

“Hazardous Motions are machinery motions and actions that can cause injury to employees.”

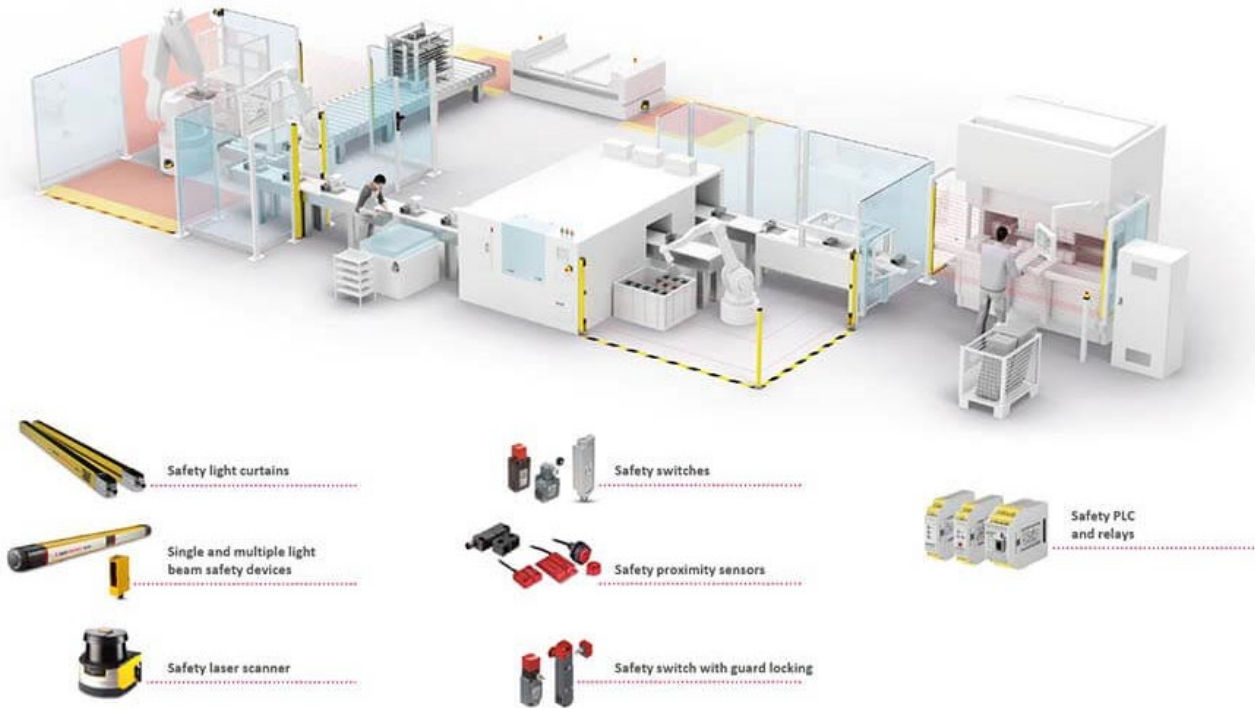

- **Rotating Motion:** This includes parts like shafts, couplings, and gears that rotate.
- **In-Running Nip Points:** These occur where two parts rotate in opposite directions and are close together, such as between rollers or gears.
- **Reciprocating Motion:** This involves back-and-forth or up-and-down movements, such as those found in presses or saws.
- **Transversing Motion:** This is a straight, continuous movement, like conveyor belts.

Source OSHA

# Hazardous Motions - Rotation

- *Rotating parts* with hazardous projections

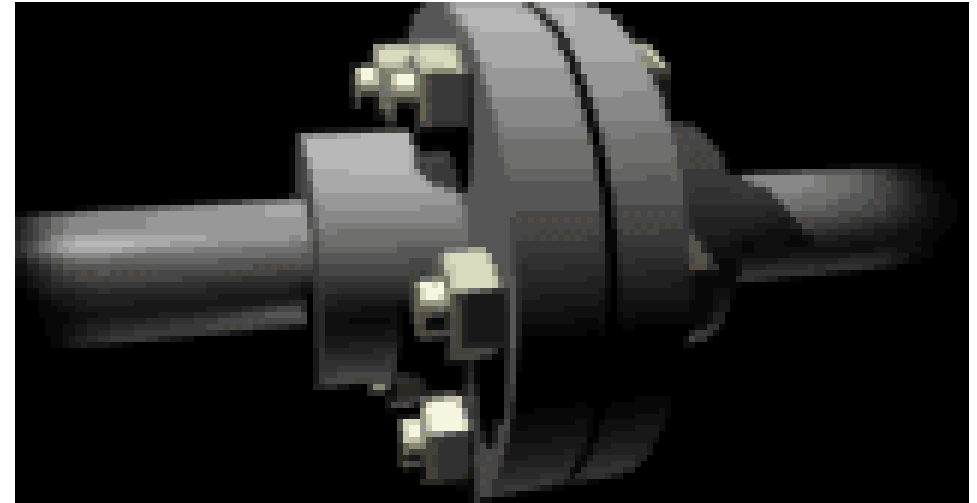
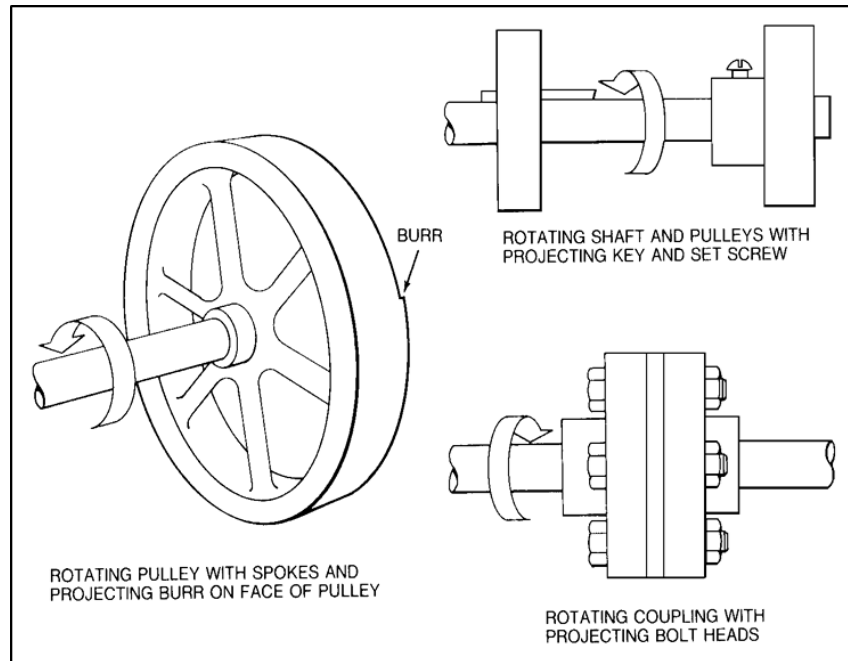

Source – OSHA

# Hazardous Motions – Nip Points

- Common *Nip points* on rotating parts

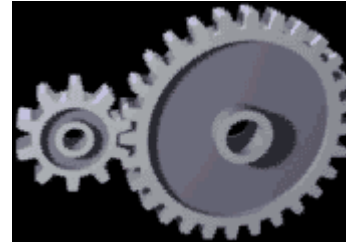

- *Nip points* between rotating elements and parts with longitudinal motions

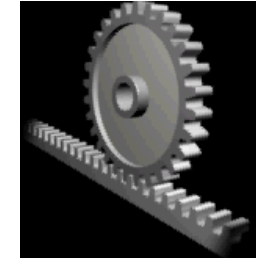
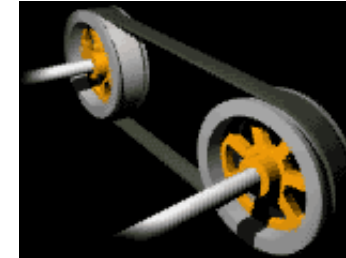
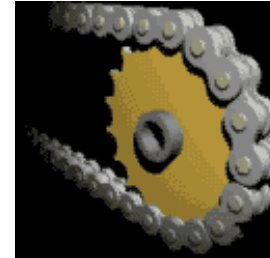

- *Nip points* between rotating machine components

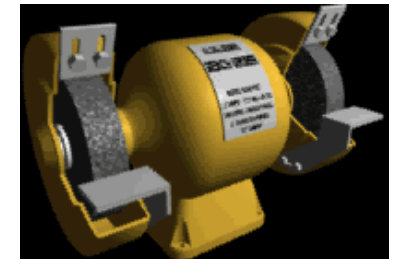
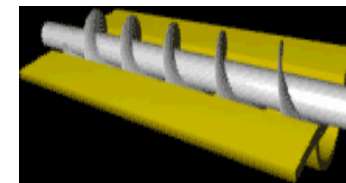

Source – OSHA

# Hazardous Motions – Reciprocating & Transverse

- **Reciprocating** motions:
  - Back-and-forth
  - Up-and-down

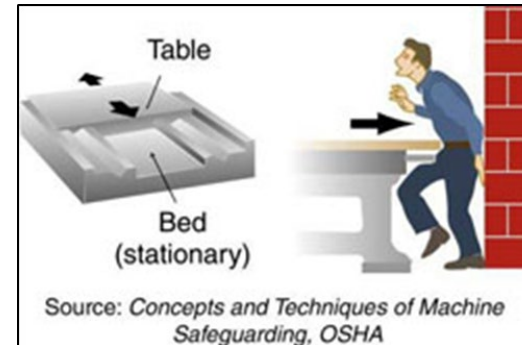

- **Transverse motion** – movement in straight, continuous line

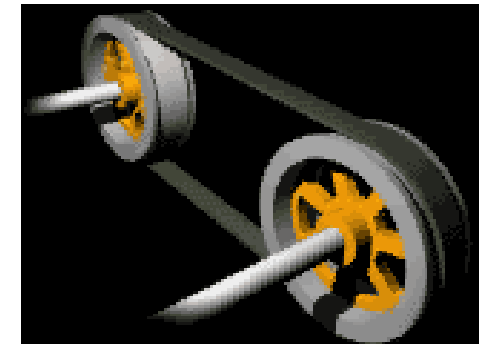
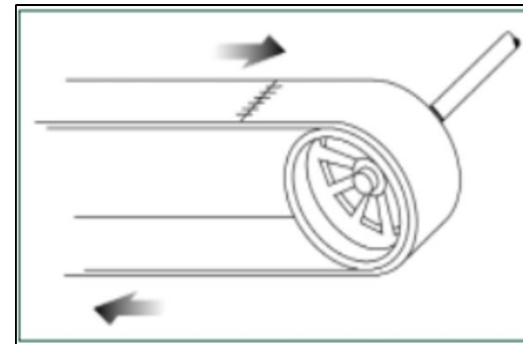

Source – OSHA

# Hazardous Actions

- **Cutting action** – may involve rotating, reciprocating, or transverse motion
- **Punching action** – power applied to a slide (ram) for purpose of blanking, drawing, or stamping metal or other materials
- **Shearing action** – applying power to a slide or knife to trim or shear metal or other materials
- **Bending action** – applying power to draw or stamp metal or other materials

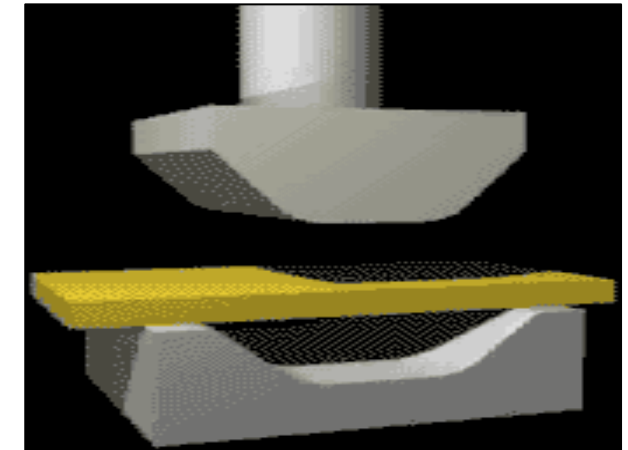
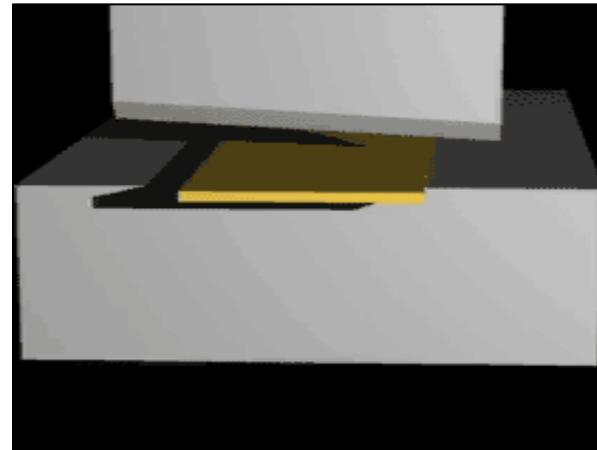
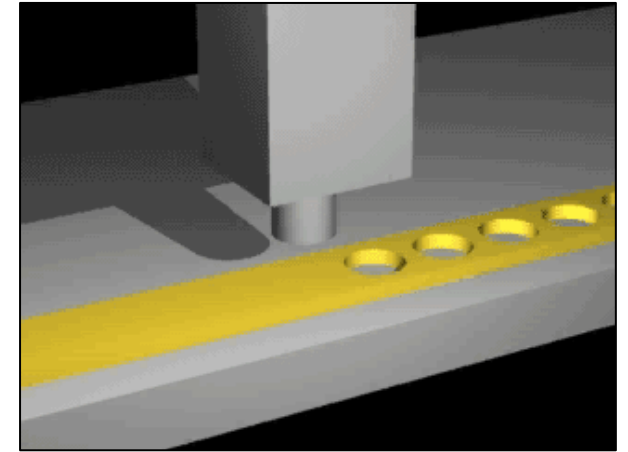
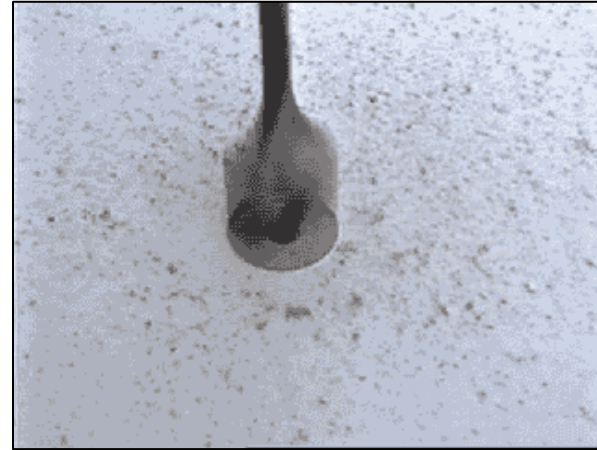

# Machines Causing Amputations



**OSHA INSTRUCTION**

**DIRECTIVE NUMBER:** CPL 03-00-019      **EFFECTIVE DATE:** 8/13/2015

**SUBJECT:** National Emphasis Program on Amputations

**ABSTRACT**

**Purpose:** This Instruction, *National Emphasis Program on Amputations*, describes policies and procedures for implementing a National Emphasis Program (NEP) to identify and to reduce workplace machinery and equipment hazards which are causing or likely to cause amputations.

**Scope:** OSHA-wide.

**References:** OSHA Instruction CPL 04-00-001, (CPL 2-0.102A) Procedures for Approval of Local Emphasis Programs, November 11, 1999.

**Cancellations:** OSHA Instruction CPL 03-00-003, National Emphasis Program on

1. Mechanical power presses
2. Power press breaks
3. Powered and non-powered conveyors
4. Printing presses
5. Roll-forming and roll-bending machines
6. Shearing machines
7. Food Slicers
8. Meat Grinders
9. Meat-Cutting Band Saws
10. Drill Presses
11. Milling Machines
12. Table Saws
13. Grinding Machines
14. Slitters”

# Machines Requiring Point of Operation Guarding

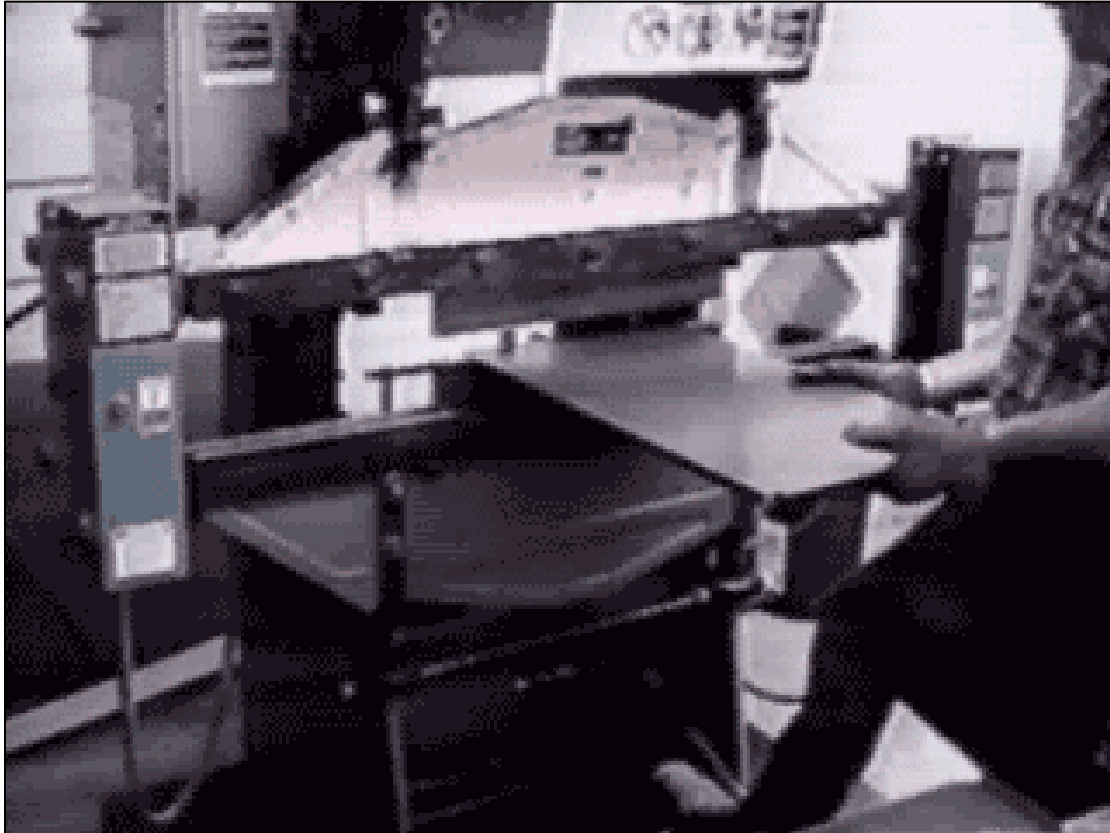

- Guillotine cutters
- Shears
- Alligator shears
- Power presses
- Milling machines
- Power saws
- Jointers
- Portable power tools
- Forming rolls and Calenders

**Installed, used, and maintained according to the manufacturer if possible.**

# Additional Machine Guarding Needs

## Revolving barrels, containers, & drums:

- Guard by an enclosure which is interlocked with drive mechanism
- Guards with openings no larger than ½”



## Power-transmission apparatus:

- Shafting, flywheels, pulleys, belts, chain drives, etc.
- Less than 7 feet from the floor or working platform must be guarded



# Additional Machine Guarding Needs

- Fan Blades

- Exposure of fan blades:

- Guard when periphery of blades is less than 7' above the floor or working level
    - Guards with openings no larger than ½"

- Abrasive Wheel Machinery

- Abrasive wheel machinery:

- Adjustable tongue guard to within ¼" of wheel
    - Work rest with maximum opening of 1/8"
    - Cover spindle end, nut, flange projections

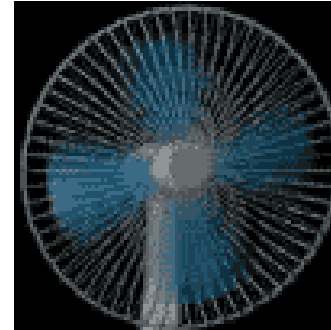

Make sure the manufacturer's recommended speed, as posted on the wheel, is compatible with your grinder

Always protect your eyes-- wear only an eye or face shield bearing the logo Z-87

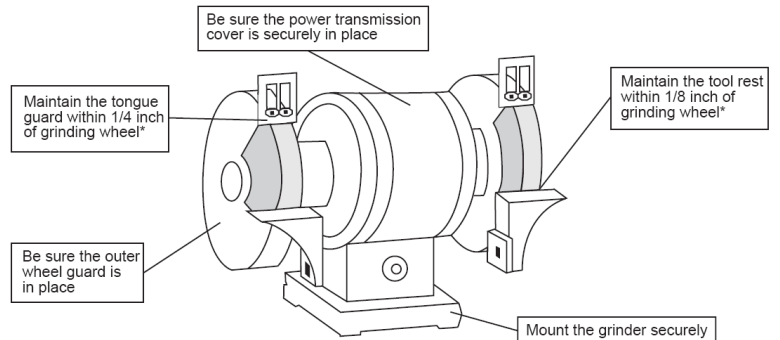

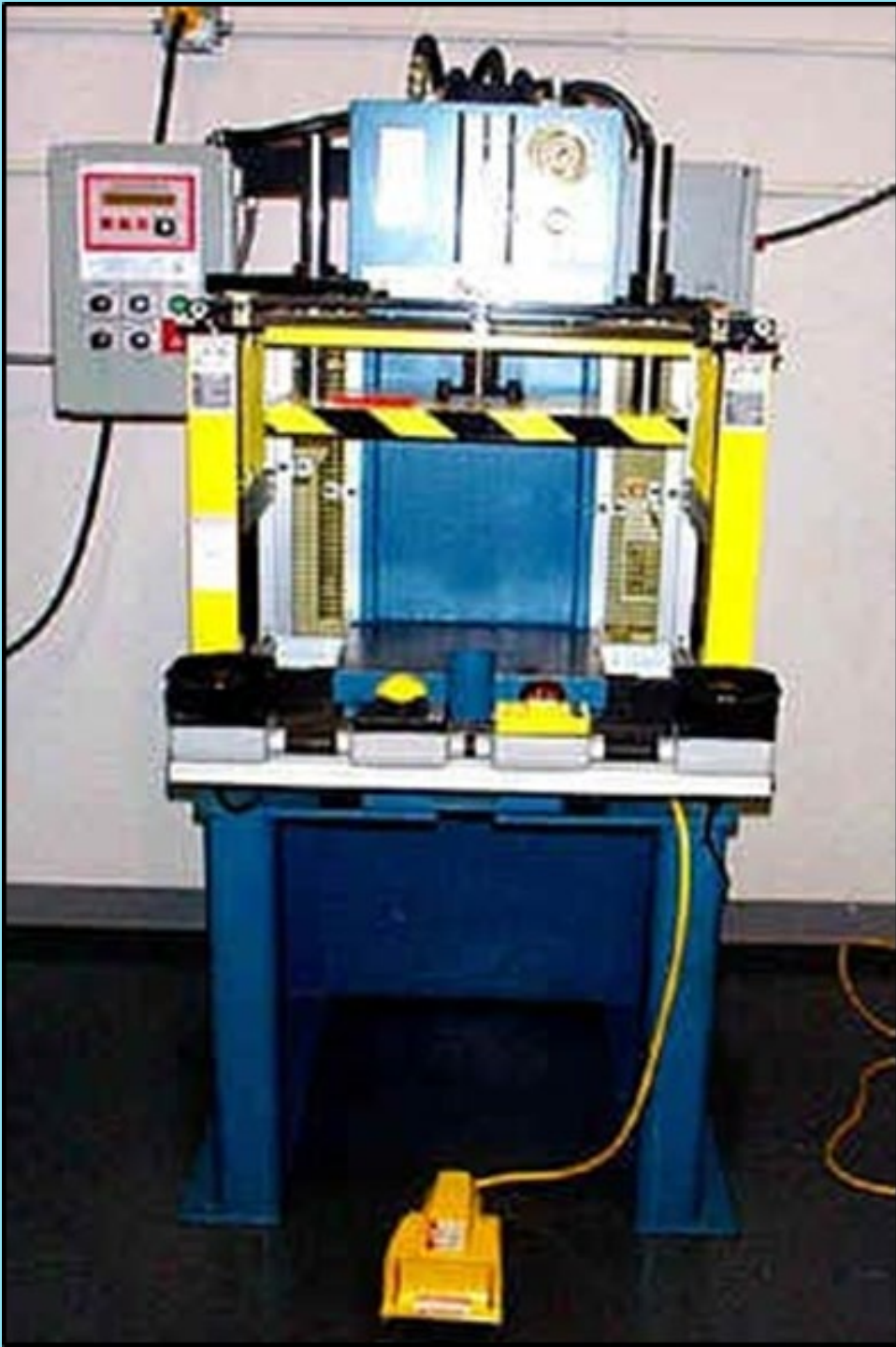

# Requirements for Safeguards

Safeguards must meet these minimum general requirements:

- Prevent contact
- Be secured
- Protect from falling objects
- Create no new hazards
- Create no interference
- Allow safe lubrication

Source: OSHA

# Types of Safeguards

- **Primary methods**
  - Guards
  - Devices
- **Ensure employee protection**
  - Properly designed, constructed, and installed
  - Used and maintained in good operating condition
- **Secondary methods**
  - Probe detection and safety edge devices
  - Awareness devices
  - Safeguarding methods
    - Safe distance
    - Safe holding
    - Safe opening
  - Safe work practices
- **Safe work procedures**
- **Complementary equipment**

# Machine Guards

## Guards:

- Preferable to other control methods
- Provide physical barrier that prevents contact with dangerous machine parts
- Four general types
  - Fixed
  - Interlocked
  - Adjustable
  - Self-adjusting



# Machine Guards

## Fixed Guards:

- Provides a barrier
- Permanent part of the machine, preferable to all other types of guards

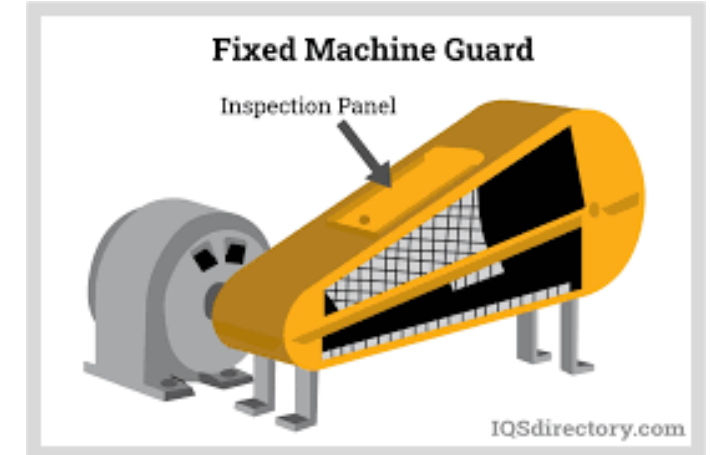

## Interlocked Guards:

- Shuts off or disengages power, stops moving parts, and prevents starting of machine when guard is open
- May use electrical, mechanical, hydraulic, or pneumatic power, or combination

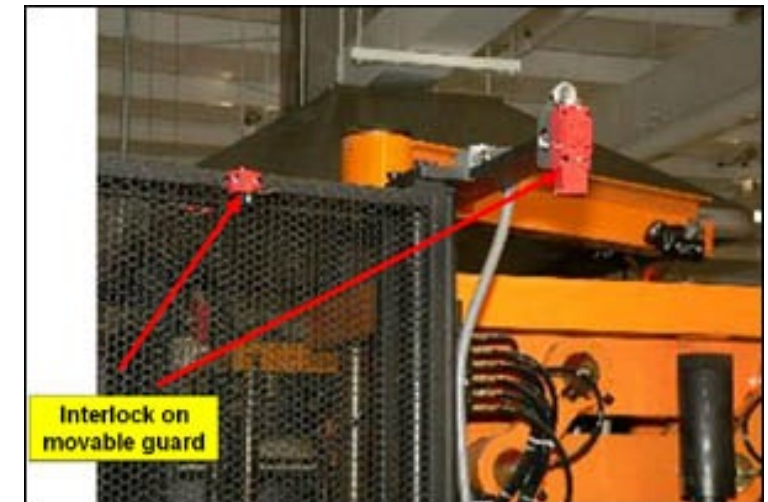

# Machine Guards

## Adjustable Guards:

- Allow flexibility in accommodating various sizes of stock
- Provides a barrier that may be adjusted to facilitate a variety of production operations



Bandsaw blade adjustable guard

## Self Adjusting Guards:

- Openings of barriers determined by movement of the stock
- Places barrier between danger area and operator



Circular table saw self-adjusting guard

# Safety Devices

## Safety Devices:

- Controls or attachments that prevent inadvertent access by employees to hazardous machine areas
  - Presence sensing
  - Photoelectric
  - Radiofrequency
  - Electromechanical
  - Pullback
  - Restraint
  - Safety trip controls
  - Two-hand control
  - Two-hand trip
  - Gate

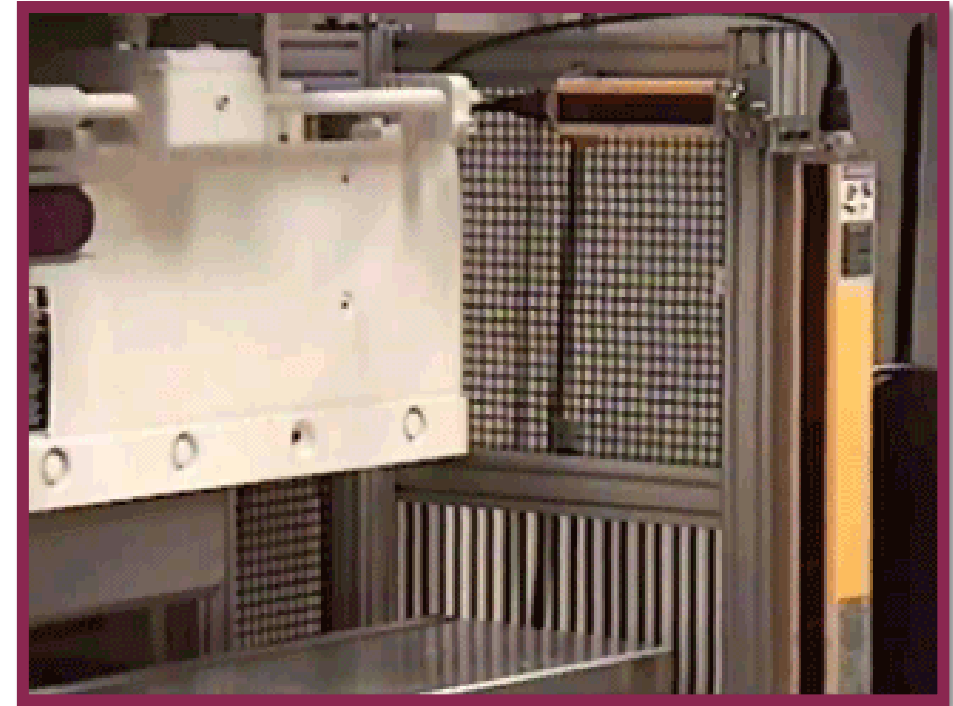

# Safety Devices – Presence Sensing

## Presence Sensing Devices

- Photoelectric
- Radiofrequency
- Electromechanical

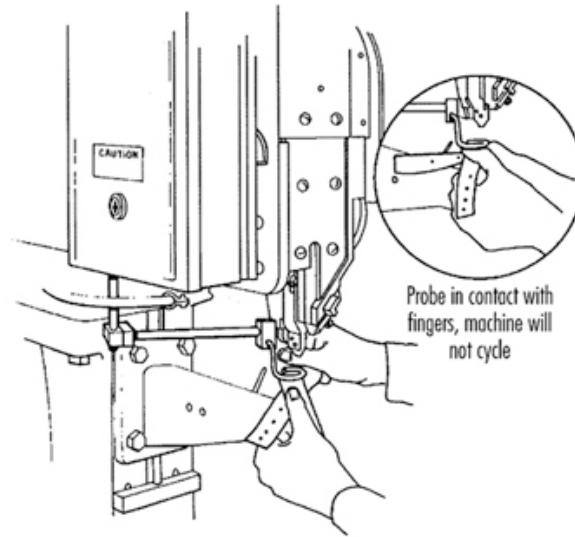
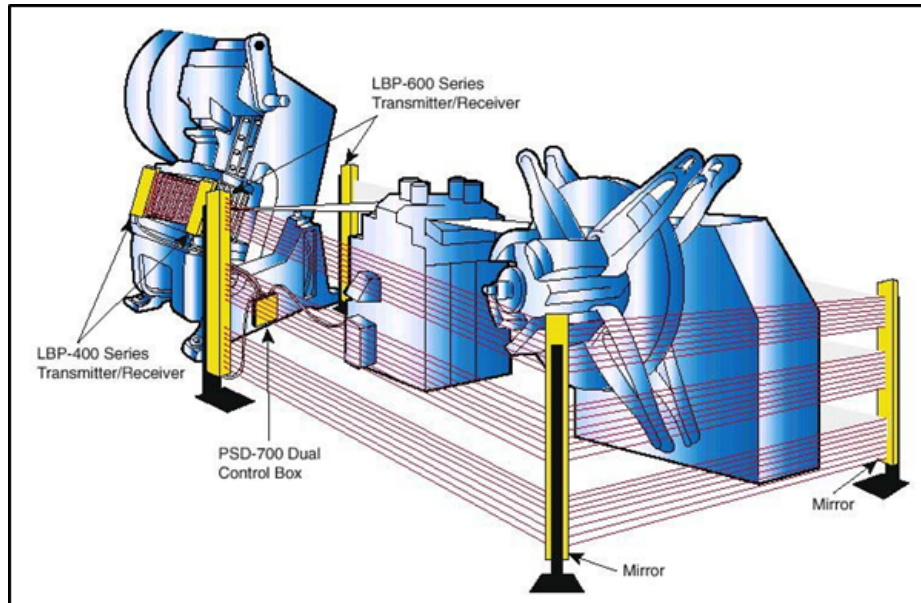

# Safety Devices: Pullbacks and Restraints

## Pullbacks:

- Utilize a series of cables attached to operator
- Automatically withdraws hands from point of operation when slide/ram begins to descend



## Restraints:

- Utilize cables/straps attached to operator's hands and a fixed point
- No extending/retracting action involved
- Hand-feeding tools may be necessary

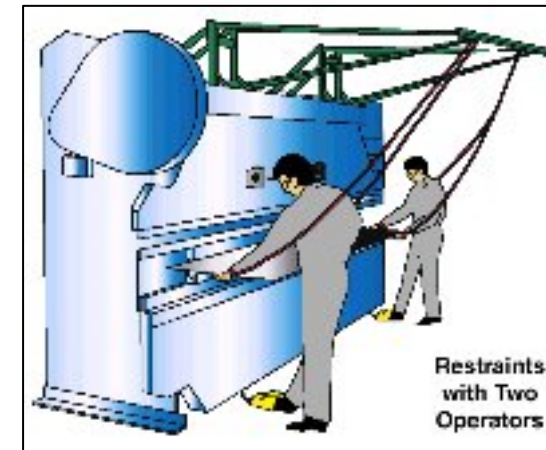

# Pullback Process



Source: OSHA

- Hands in die, feeding
- Point of operation exposed
- Pullback device attached and properly adjusted



Source: OSHA

- Die closed
- Hands withdrawn from point of operation by pullback device

# Safety Devices - Safety Trip Controls

- Deactivates the machine in an emergency
  - Pressure-sensitive bar
  - Safety tripod
  - Safety tripwire
  - Positioning is critical; must stop machine before body reaches danger area



# Safety Devices – Two Hand Controls

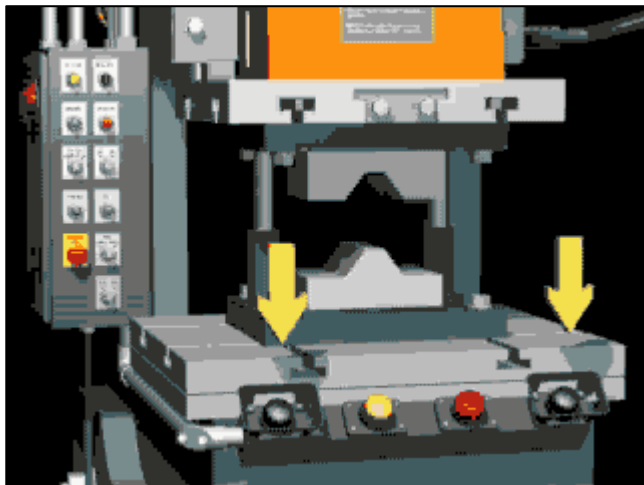

- **Two Hand Controls**

- Prevents accidental activation by requiring simultaneous use of both hands.
- Ensures operator's hands are away from dangerous moving parts.
- Reduces risk of injury by enforcing safe operating procedures.

# Safety Devices – Gate Devices

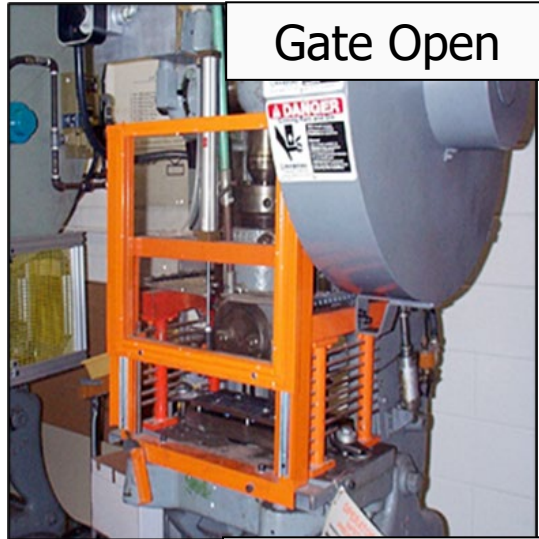

Gate Open



Gate Closed

- **Gate Devices**

- Moveable barrier that protects operator at point of operation before machine cycle can be started
- Must be interlocked so machine cannot begin cycle unless gate guard is in place
- Must be closed before machine can function
  - “A” Gate
  - “B” Gate

# Safety Devices – Gate Devices

Type “A” Gate Operation

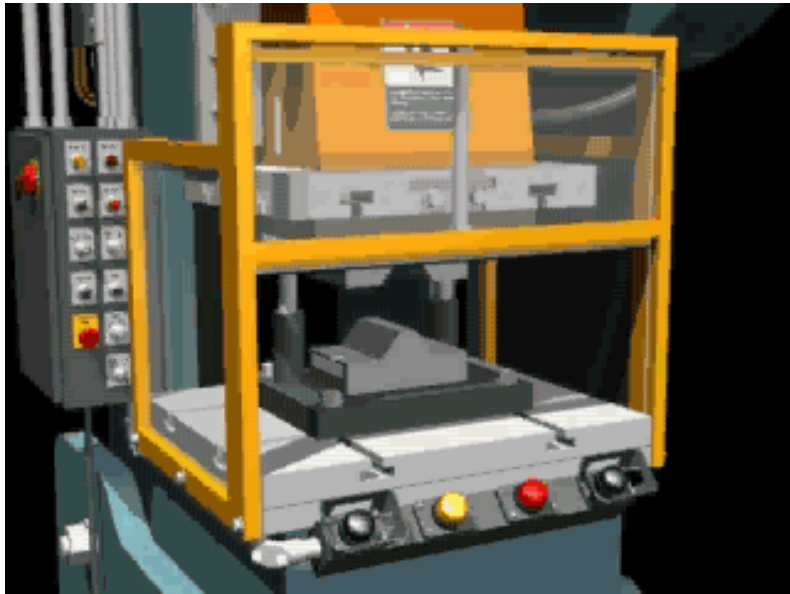

Type “B” Gate Operation

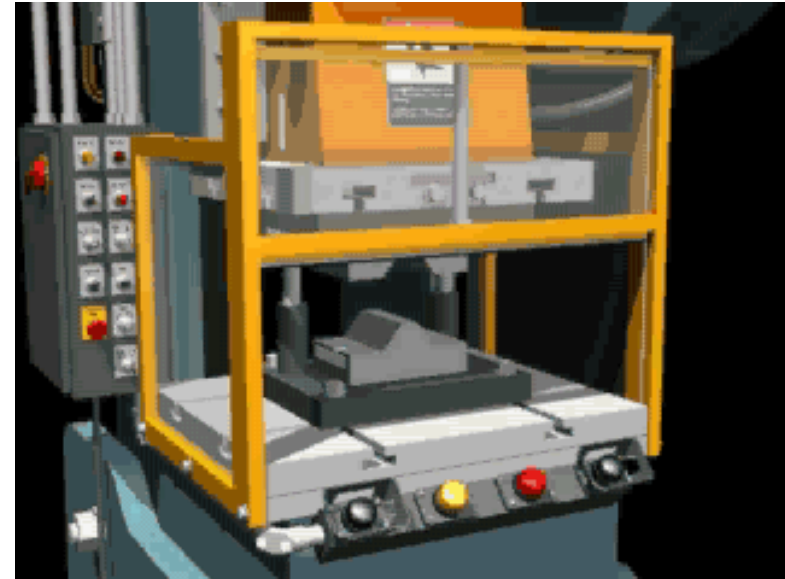

Source of graphics: OSHA

# Additional Safeguards

## Location/distance:

- The dangerous moving part of a machine must be so positioned that those areas are not accessible or do not present a hazard
- Feeding process safeguarded by maintaining safe distance to protect worker
- Operator's controls located safe distance from machine



# Additional Safeguards

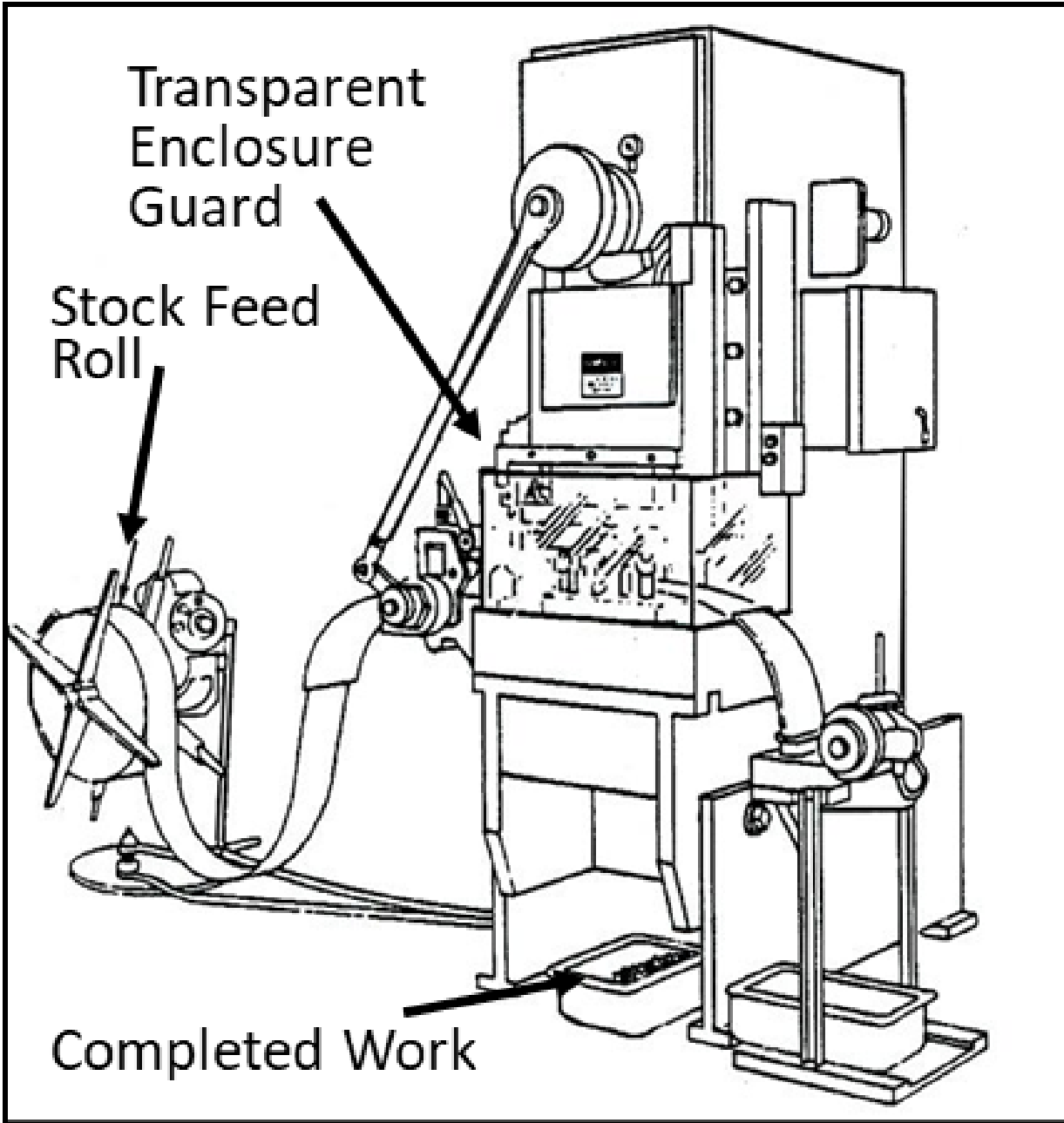

## Feeding and ejection methods:

- Automatic & semi-automatic feed
- Automatic & semi-automatic ejection
- Robots

# Additional Safeguards

## Miscellaneous aids:

- Awareness barriers
- Protective shields
- Hand-feeding tools

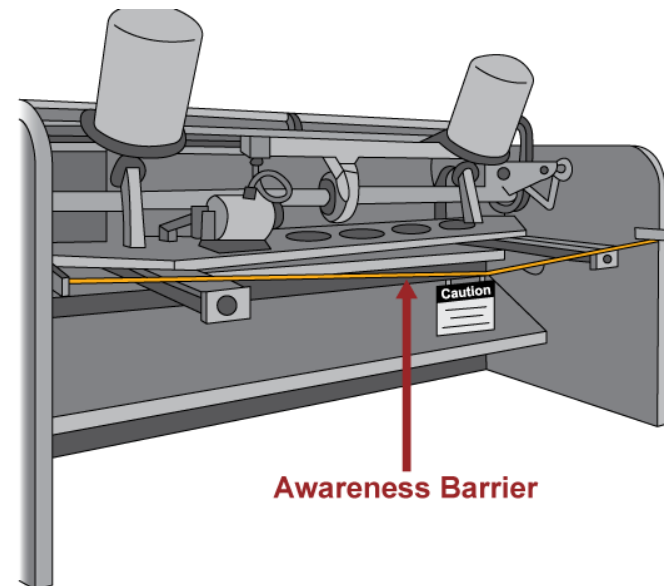
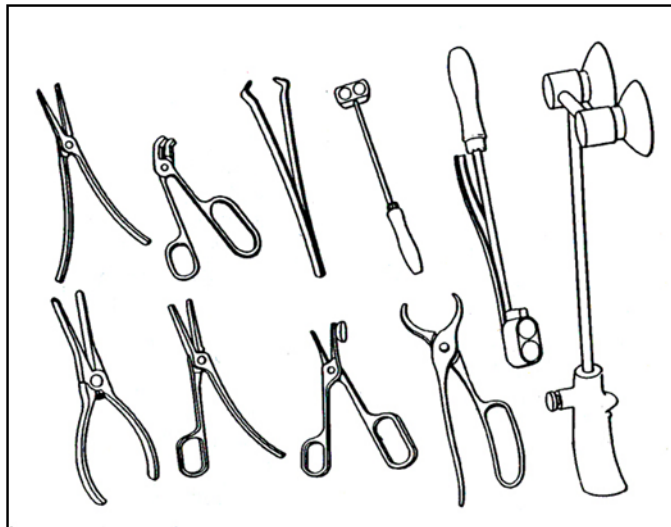
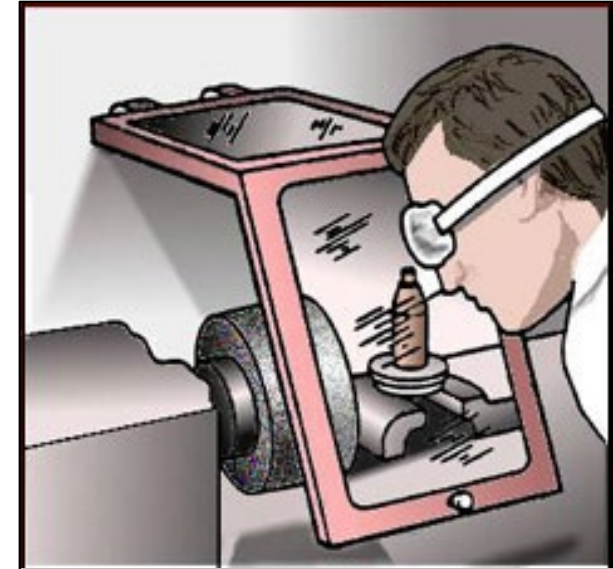

# Hazard Recognition for Machinery Hazards

- 1. Comprehensive Risk Assessment:** Conducting thorough risk assessments to identify potential hazards associated with machinery.
- 2. Regular Inspections:** Performing regular inspections of machinery to detect wear, malfunctions, and unsafe conditions.
- 3. Documentation Review:** Reviewing manuals, manufacturer instructions, and training materials to understand the machinery's design, operation, and maintenance requirements.
- 4. Employee Training:** Providing comprehensive training for employees on hazard recognition, safe operating procedures, and emergency response.
- 5. Use of Safety Devices:** Implementing safety devices such as machine guards, interlocks, and emergency stop controls to prevent access to hazardous areas and reduce the risk of injury.
- 6. Observation and Feedback:** Encouraging employees to observe and report potential hazards.
- 7. Advanced Technologies:** Utilizing advanced technologies like sensors, cameras, and software to monitor machinery and detect hazards in real-time.



What if the guards and safety devices must be removed?

# Zero Energy State

---



# Lockout

*The specific practices and procedures necessary to disable machinery and equipment so that employees performing service and maintenance activities are protected*

*OSHA 1910.147 The Control of Hazardous Energy*

# 44%

Of caught in machinery injuries could be prevented with Lockout

## Service or Maintenance

- **Installation:** Setting up machinery or equipment, which may involve connecting power sources and ensuring proper operation
- **Inspection:** Examining machinery or equipment to identify any issues or potential hazards
- **Cleaning:** Removing debris, dust, or contaminants from machinery or equipment to ensure proper functioning
- **Repair:** Fixing any broken or malfunctioning parts of machinery or equipment
- **Adjustment:** Making changes to machinery or equipment settings to ensure optimal performance
- **Modification:** Altering machinery or equipment to improve functionality or adapt to new processes
- **Lubrication:** Applying lubricants to machinery or equipment to reduce friction and wear
- **Unjamming:** Clearing blockages or jams in machinery or equipment to restore normal operation
- **Troubleshooting:** Diagnosing and resolving issues with machinery or equipment

Activities Being Performed - Caught in Machinery

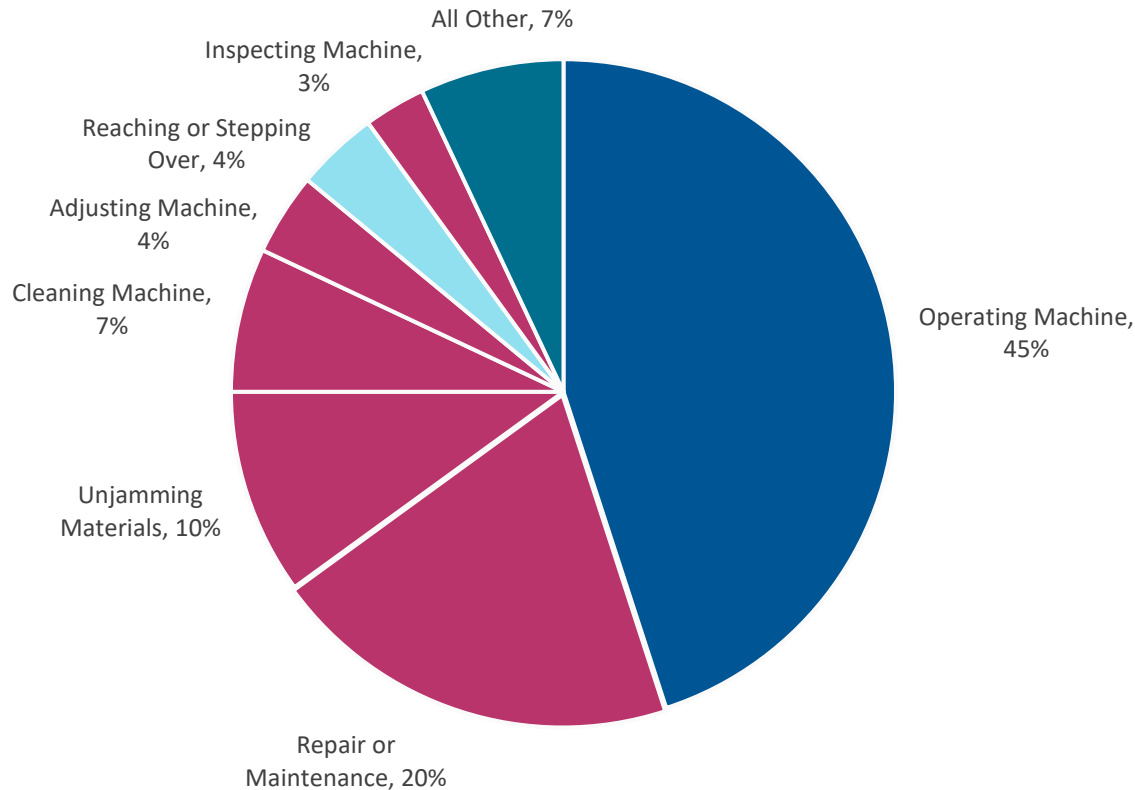

# Energy to be Controlled

It takes more than just disconnecting Electrical to achieve Zero Energy!

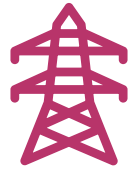

Electrical



Mechanical



Pneumatic



Thermal



Hydraulic



Chemical

# Steps to Zero Energy

The following are the steps to achieve Zero Energy

**Notify Employees:**  
Inform all affected employees that the machinery will be shut down and locked out

**Shut Down Machinery:**  
Follow the standard procedure to turn off the machinery

**Isolate Energy Sources:**  
Disconnect or isolate all energy sources

**Apply Lockout Devices:**  
Attach lockout devices to energy isolation points

**Release Stored Energy:**  
Safely release any residual or stored energy

**Verify Zero Energy State:** Test the machinery to confirm that all energy sources have been effectively isolated, and that the machinery cannot be started



# Lockout Tagout

## Additional Needs for Lockout Tagout



Conduct Assessment and Develop Equipment Specific Procedures



Formal Written Program and Procedures



Train Authorized and Affected Employees

June 2025

1. Understand the common hazards associated with moving machinery
2. Review the regulations and standards for machine safeguarding
3. Discuss the components of strong hazard recognition for machinery hazards
4. Identify the necessary steps to achieve a Zero Energy State when working on machinery

# Questions?

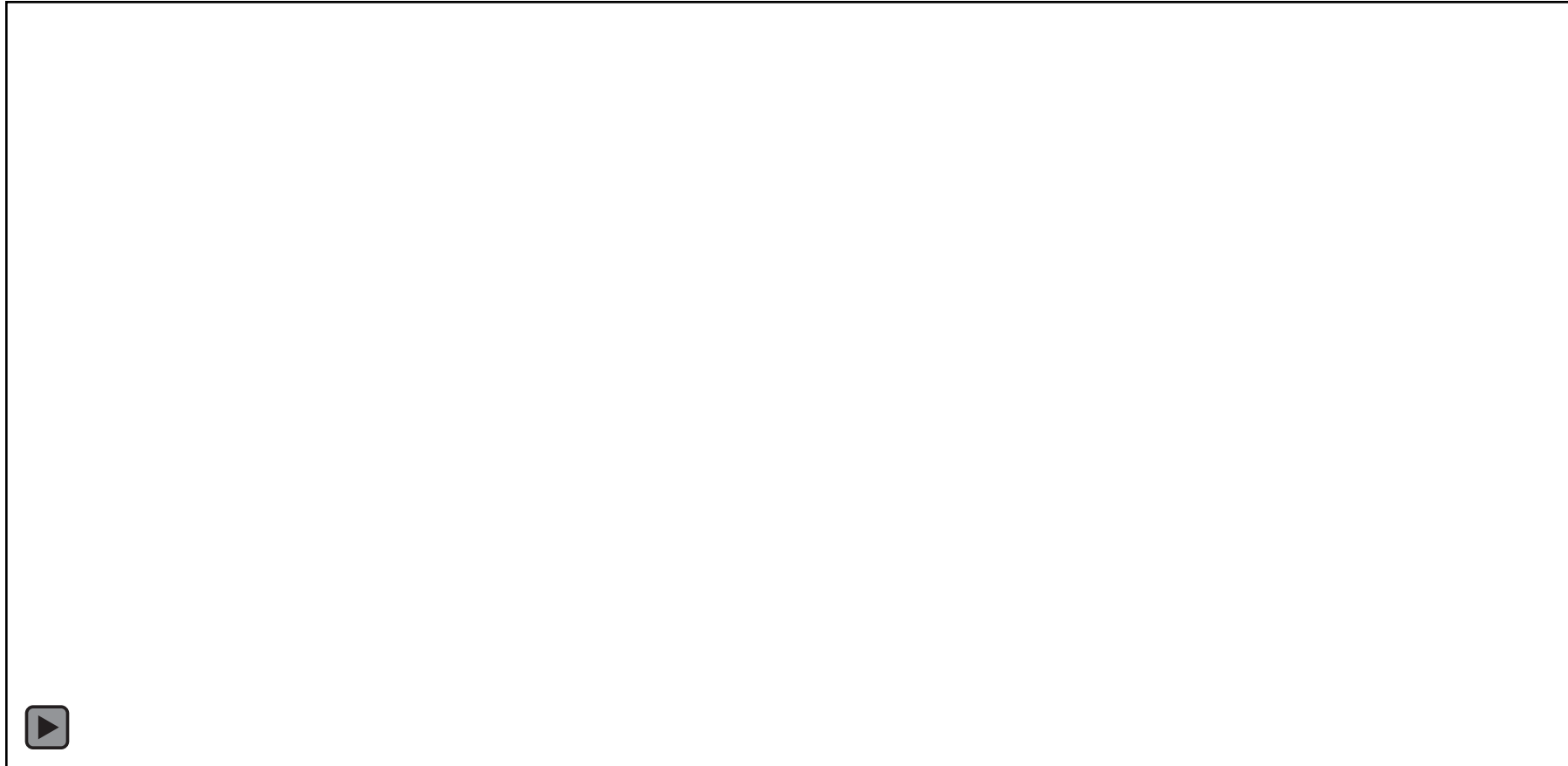

Please email questions to [losscontrol@bhhc.com](mailto:losscontrol@bhhc.com)



**Berkshire Hathaway**  
HOMESTATE COMPANIES

Workers Compensation Division <sup>TM</sup>

PC23  
LAKE TAHOE

