

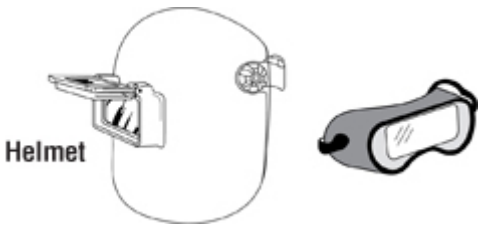



# Welding – Personal Protective Equipment and Clothing Fact Sheet



## WHAT TYPE OF PPE IS AVAILABLE WHEN WELDING?

The chart below summarizes the types of personal protective equipment that can be used when welding.

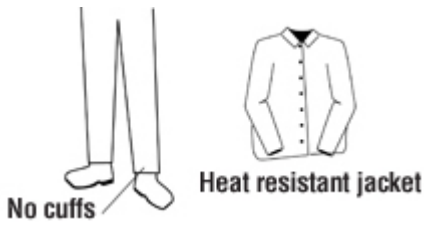
Welding – Personal Protective Equipment			
Body Part	Equipment	Illustration	Reason
Eyes and face	Welding helmet, hand shield, or goggles	 <p>Helmet</p>	<p>Protects from:</p> <ul style="list-style-type: none"> <li>• radiation</li> <li>• flying particles, debris</li> <li>• hot slag, sparks</li> <li>• intense light</li> <li>• irritation and chemical burns</li> </ul> <p>Wear fire resistant head coverings under the helmet where appropriate</p>

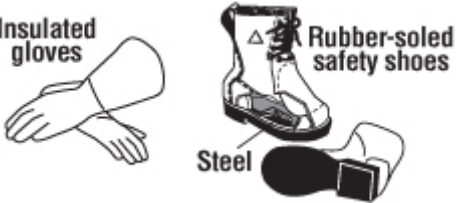
<p><b>Lungs (breathing)</b></p>	<p><b>Respirators</b></p>		<p><b>Protects against:</b></p> <ul style="list-style-type: none"> <li>• fumes and oxides</li> </ul>
<p><b>Exposed skin (other than feet, hands, and head)</b></p>	<p><b>Fire/Flame resistant clothing and aprons</b></p>		<p><b>Protects against:</b></p> <ul style="list-style-type: none"> <li>• heat, fires</li> <li>• burns</li> <li>• radiation</li> </ul> <p><b>Notes:</b>  pants should not have cuffs, shirts should have flaps over pockets or be taped closed</p>
<p><b>Ears – hearing</b></p>	<p><b>Ear muffs, ear plugs</b></p>	 <p><b>Ear protection</b></p>	<p><b>Protects against:</b></p> <ul style="list-style-type: none"> <li>• noise</li> </ul> <p>Use fire resistant ear muffs where sparks or splatter may enter the ear, rather than plugs.</p>
<p><b>Feet and hands</b></p>	<p><b>Boots, gloves</b></p>		<p><b>Protects against:</b></p> <ul style="list-style-type: none"> <li>• electric shock</li> <li>• heat</li> <li>• burns</li> <li>• fires</li> </ul>

**WHY IS EYE PROTECTION IMPORTANT?**

Eye injury can occur from the intense light and radiation that a welding arc can produce. Eye injury can also occur from hot slag and other metal debris that can fly off from the weld during cooling, chipping or grinding.

- Protect your eyes from welding light by wearing a welder's helmet fitted with a

filter shade that is suitable for the type of welding you are doing.

- ALWAYS wear safety glasses with side shields or goggles when chipping or grinding a work piece if you are not wearing a welding helmet.

#### **WHAT TYPE OF EYE AND FACE PROTECTION IS APPROPRIATE FOR MY WELDING TASK?**

The various types of eye protection are broken down into classes in the CSA standard Z94.3-15 "Eye and face protectors". Each class is designed for a specific use. Eye and face protectors should have distinctive markings to identify the manufacturer and their class. Classifications of common protectors for welding operations are listed below:

- Class 2C – direct / non-ventilated goggles with non-ionizing radiation protection
- Classes 3 and 4 – welding helmets and hand shields
- Class 6B – face shields for non-ionizing radiation protection
- Class 7B – respirator facepiece for non-ionizing radiation protection

The following operations require full face protection by using either a welding helmet or a hand shield:

- arc welding,
- plasma arc cutting, gouging or welding, and
- air carbon arc cutting.

For gas cutting, welding, or brazing, the intensity of the light is much less than from arc welding, cutting or gouging processes. Lighter shade filter lenses can be used with goggles in place of a helmet.

#### **WHAT ARE THE VARIOUS COMPONENTS OF WELDING HAND SHIELDS AND HELMETS?**

Hand shields or helmets provide eye protection by using an assembly of components:

- Helmet shell – must be opaque to light and resistant to impact, heat and electricity.
- Outer cover plate made of polycarbonate plastic which protects from radiation, impact and scratches.
- Filter lens made of glass containing a filler which reduces the amount of light passing through to the eyes. Filters are available in different shade numbers ranging from 2 to 14. The higher the number, the darker the filter and the less light passes through the lens.
- Clear retainer lens made of plastic prevents any broken pieces of the filter lens from reaching the eye.
- Gasket made of heat insulating material between the cover lens and the filter lens protects the lens from sudden heat changes which could cause it to break. In some models the heat insulation is provided by the frame mount instead of a separate gasket.

## Welders Helmet

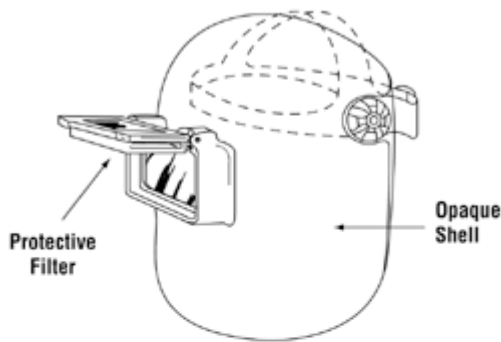

## Eye protection assembly

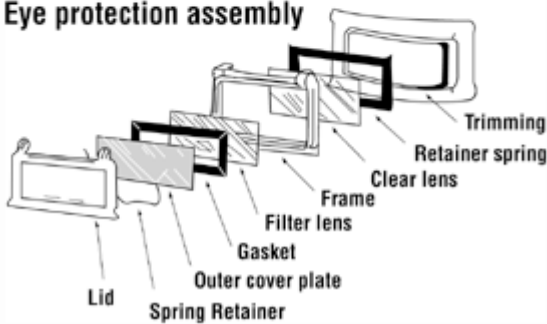

## WHAT ELSE SHOULD YOU KNOW ABOUT EYE PROTECTION?

- Choose a tight fitting helmet to help reduce light reflection into the helmet through the space between the shell and the head.
- Wear the helmet correctly. Do not use it as a hand shield.
- Protect the shade lens from impact and sudden temperature changes that could cause it to crack.
- Use a cover lens to protect the filter shade lens. Replace the cover lens if it gets scratched or hazy.
- Make sure to replace the gasket periodically if your helmet uses one.
- Replace the clear retaining lens to protect your eyes from broken pieces.
- Clean lenses periodically.
- Discard pitted, cracked or damaged lenses.

## WHAT SHOULD YOU KNOW ABOUT FILTER SHADE SELECTION?

For Arc welding, the correct filter shade is selected according to the welding process, wire diameter, and operating current. The table below gives the correct shade numbers for different situations.

- ALWAYS use suggested shade numbers instead of minimum shade numbers. The values below are from CSA Standard W117.2-12 Safety in welding, cutting and allied processes. Other processes are listed in the Standard.

### Shade Numbers for Selected Arc Processes (from CSA W117.2)

Process	Electrode Diameter (mm)	Current (Amperes)	Minimum Shade	Suggested Shade
SMAW	< 2.5	< 60	7	-
	2.5 - 4	60 - 160	8	10
	4 - 6.4	160 - 250	10	12
	> 6.4	250 - 550	11	14
GMAW FCAW MCAW		< 60	7	-
		60 - 160	10	11
		160 - 250	10	12
		250 - 500	10	14
Air Carbon Arc Cutting light heavy		< 500	10	12
		500 - 1000	11	14

*\*In the United States use ANSI/AWS Standard F2.2 for selecting filter lens shades.*

- Provide additional task lighting that suits welders' needs.
- Use the same shade as the welder's if you are directly observing the welding arc.
- Do not use gas welding goggles for arc welding.
- Do not substitute modified glasses, sunglasses, smoked plastic or other materials for proper welding lenses.

The recommended shade numbers for oxygen cutting are shown in the table below.

### Shade Numbers for Cutting (from CSA W117.2)

Process	Plate Thickness (in mm)	Minimum Shade #	Suggested Shade #
Light	< 25	3	4
Medium	25 - 150	4	5
Heavy	> 150	5	6

*\* In the US use ANSI/AWS Standard F2.2 for selecting filter lens shade.*

### CAN YOU WEAR CONTACT LENSES WHEN WELDING?

The CSA Standard W117.2 states that contact lenses should not be worn by welders and welding personnel because foreign bodies (objects) in the eye can cause excessive irritation. Contact lenses do not provide protection from ultraviolet radiation and flying objects. All workers in proximity to welding procedures must wear appropriate eye protection according to the circumstances.

### WHAT MEASURES CAN PROTECT SKIN FROM WELDING RADIATION?

- Wear tightly woven work-weight fabrics to keep UV radiation from reaching your skin.
- Button up your shirt to protect the skin on the throat and neck.
- Wear long sleeves and pant legs.

- Cover your head with a fabric cap to protect the scalp from UV radiation.
- Protect the back of your head by using a hood.
- Protect your face from UV radiation by wearing a tight-fitting, opaque welder's helmet.
- Make sure that all fabric garments are resistant to spark, heat and flame. Keep the fabrics clean and free of combustible materials that could be ignited by a spark.

#### **WHAT SHOULD YOU KNOW ABOUT USING RESPIRATORS WHEN WELDING?**

Respiratory protection is needed when ventilation is not sufficient to remove welding fumes or when there is risk of oxygen deficiency. Select and use respirators in compliance with applicable regulations. Seek expert advice, conduct a hazard assessment, and initiate an appropriate respiratory protection program.

The process of selecting appropriate respiratory protection is also outlined in CSA standard Z94.4 and ANSI (American National Standards Institute) standard Z88.2 "Respiratory Protection".

#### **WHAT ARE SOME TIPS TO KNOW WHEN USING PROTECTIVE CLOTHING?**

##### **DO**

- Wear clothing made from heavyweight, tightly woven, 100% wool or cotton to protect from UV radiation, hot metal, sparks and open flames. Flame retardant treatments become less effective with repeated laundering.
- Keep clothing clean and free of oils, greases and combustible contaminants.
- Wear long-sleeved shirts with buttoned cuffs and a collar to protect the neck. Dark colours prevent light reflection.
- Tape shirt pockets closed to avoid collecting sparks or hot metal or keep them covered with flaps.
- Pant legs must not have cuffs and must cover the tops of the boots. Cuffs can collect sparks.
- Repair all frayed edges, tears or holes in clothing.
- Wear high top boots fully laced to prevent sparks from entering into the boots.
- Use fire-resistant boot protectors or spats strapped around the pant legs and boot tops, to prevent sparks from bouncing in the top of the boots.
- Remove all ignition sources such as matches and butane lighters from pockets. Hot welding sparks may light the matches or ignite leaking lighter fuel.
- Wear gauntlet-type cuff leather gloves or protective sleeves of similar material, to protect wrists and forearms. Leather is a good electrical insulator if kept dry.
- Using a shield can help keep any sparks spray away from your clothing.
- Wear leather aprons to protect your chest and lap from sparks when standing or sitting.
- Wear layers of clothing. To prevent sweating, avoid overdressing in cold weather. Sweaty clothes cause rapid heat loss. Leather welding jackets are not very breathable and can make you sweat if you are overdressed.
- Wear a fire-resistant skull cap or balaclava hood under your helmet to protect your head from burns and UV radiation.
- Wear a welder's face shield to protect your face from radiation and flying particles.

##### **DO NOT**

- Do not wear rings or other jewellery.
- Do not wear clothing made from synthetic or synthetic blends. The synthetic

fabric can burn vigorously, melt and produce bad skin burns.

*Source: © Copyright 1997-2021 CCOHS*