

MMH – Hoisting and Moving Heavy Objects Fact Sheets



WHAT EQUIPMENT CAN BE USED TO HELP WITH HEAVY OBJECTS?

Selecting the right equipment for the task minimizes handling.

- Use a cart, trolley or platform.
- Consider carts with hand brakes for more control on inclines, or powered hand carts for stairs.
- Use carts designed for specific purposes (e.g. holding cylinders) as needed.

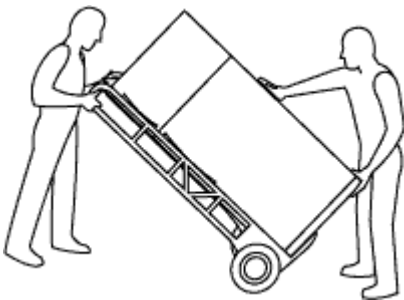

- Use a pulley to eliminate manual lifting.
- Select multiple pulleys according to the weight of the object to be hoisted.
- Mount pulley on movable frame to lift and move heavy objects.

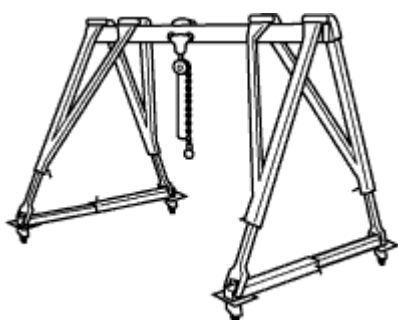
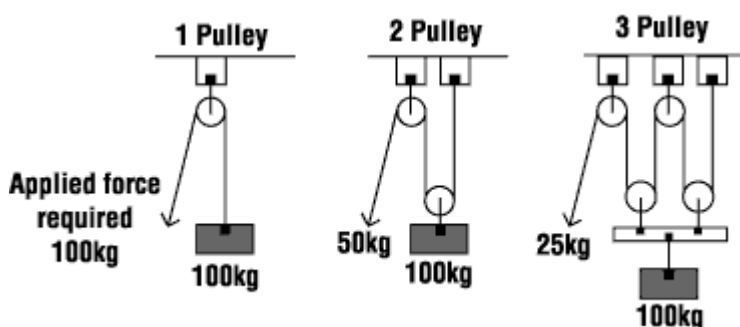

- Use a portable hoist or floor crane to lift and move heavy objects.
- Use lifting magnets in combination with hoists where appropriate.

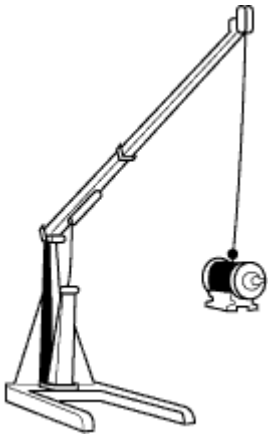

- Use lift tables to lift objects or to level work.
- Select the lift table according to the weight of the anticipated load.

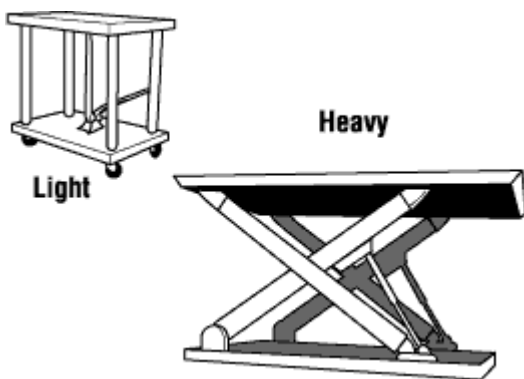

- Use a portable conveyor to move materials.

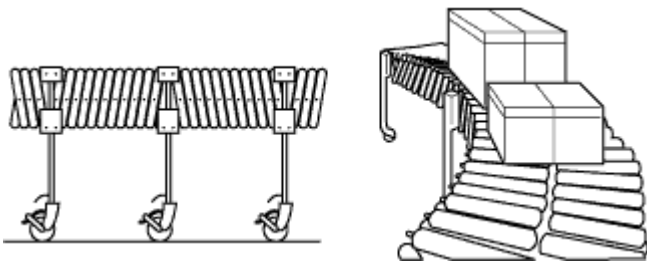

- Use a combination of lift tables and rollers to move materials horizontally and vertically.

